

2 くい込み式管継手

溶接フレアドユニオン UW

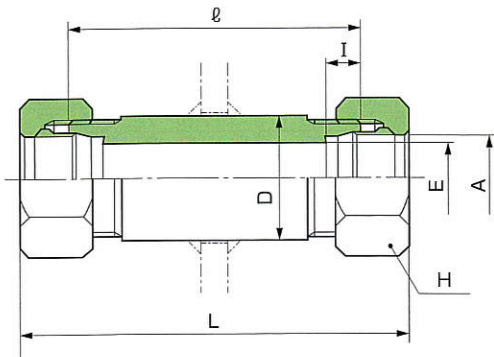

継手の呼び	適用管外径A		E	D	六角対辺H		I	ℓ	手締めL(約)
	呼び径	外径							
UW - 6	6		4	16	14	7	74	95	
UW - 8	8		6	16	17	7	74	95	
UW - 10	10		8	19	19	7	74	97	
UW - 12	12		10	20	22	7	74	97	
UW - 15	15		12	26	27	7.5	78	103	
UW - 16	16		13	28	30	7.5	78	103	
UW - 18	18		14	28	32	8	78	103	
UW - 20	20		17	32	36	8	78	103	
UW - 22	22		18	32	36	9	78	103	
UW - 25	25		20	38	41	10	78	105	
UW - 28	28		22	39	46	10	82	110	
UW - 30	30		25	46	46	10	82	111	
UW - 32	32		26	46	50	11	82	111	
UW - 35	35		28	46	55	11	82	117	
UW - 38	38		32	55	60	12	82	121	
UW - 40	40		32	55	60	12	90	129	
UW - 50	50		40	65	75	12	90	133	
UW - 1/8	1/8	10.5	8	19	19	7	74	97	
UW - 1/4	1/4	13.8	11	22	24	7.5	78	102	
UW - 3/8	3/8	17.3	14	28	32	8	78	103	
UW - 1/2	1/2	21.7	18	32	36	9	78	103	
UW - 3/4	3/4	27.2	22	39	46	10	82	110	
UW - 1	1	34.0	28	46	55	11	82	117	
UW - 1 1/4	1 1/4	42.7	34	58	65	12	90	131	
UW - 1 1/2	1 1/2	48.6	40	65	75	12	90	133	

※Average Values

※上記諸元は品質の向上により若干変わることがあります。

ハーフユニオン S

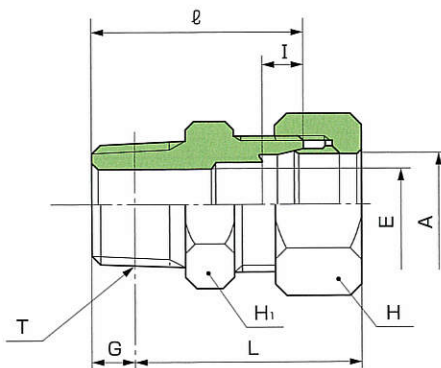

継手の呼び	適用管外径A		(PT) T	E	基準径の位置G		六角対辺H		I	ℓ	手締めL(約)
	呼び径	外径			H ₁	H					
S - 4x1/8	4		1/8	2.5	3.97	12	12	6	22	25.5	
S - 6x1/8	6		1/8	4	3.97	14	14	7	28	34.5	
S - 6x1/4	6		1/4	4	6.01	14	14	7	33	37.5	
S - 8x1/8	8		1/8	4	3.97	17	17	7	29	35.5	
S - 8x1/4	8		1/4	6	6.01	17	17	7	33	37.5	
S - 10x1/4	10		1/4	7	6.01	17	19	7	33	38.5	
S - 10x3/8	10		3/8	8	6.35	19	19	7	34	39	
S - 10x1/2	10		1/2	8	8.16	22	19	7	39	42.5	
S - 12x1/4	12		1/4	7	6.01	19	22	7	33	38.5	
S - 12x3/8	12		3/8	9	6.35	19	22	7	34	39	
S - 12x1/2	12		1/2	10	8.16	22	22	7	39	42.5	
S - 15x3/8	15		3/8	9	6.35	24	27	7.5	37	43	
S - 15x1/2	15		1/2	12	8.16	24	27	7.5	41	45.5	
S - 16x3/8	16		3/8	9	6.35	27	30	7.5	37	43	
S - 16x1/2	16		1/2	12	8.16	27	30	7.5	41	45.5	
S - 18x3/8	18		3/8	9	6.35	27	32	8	37	43	
S - 18x1/2	18		1/2	12	8.16	27	32	8	41	45.5	
S - 20x1/2	20		1/2	12	8.16	30	36	8	43	47.5	
S - 20x3/4	20		3/4	16	9.53	30	36	8	45	48	
S - 22x1/2	22		1/2	12	8.16	32	36	9	43	47.5	
S - 22x3/4	22		3/4	16	9.53	32	36	9	45	48	
S - 25x3/4	25		3/4	16	9.53	36	41	10	46	50	
S - 25x1	25		1	20	10.39	36	41	10	49	52	
S - 28x3/4	28		3/4	16	9.53	41	46	10	48	52.5	
S - 28x1	28		1	22	10.39	41	46	10	51	54.5	
S - 30x1	30		1	22	10.39	41	46	10	51	55	
S - 30x1 1/4	30		1 1/4	25	12.70	46	46	10	55	57	
S - 32x1 1/4	32		1 1/4	26	12.70	46	50	11	55	57	
S - 35x1 1/4	35		1 1/4	28	12.70	46	55	11	55	60	
S - 38x1 1/2	38		1 1/2	32	12.70	50	60	12	57	64	
S - 40x1 1/2	40		1 1/2	32	12.70	55	60	12	62	69	
S - 42x1 1/2	42		1 1/2	34	12.70	55	60	12	62	69	
S - 50x2	50		2	40	15.88	65	75	12	71	76.5	
S - 1/8x1/8	1/8	10.5	1/8	4	3.97	17	19	7	29	36.5	
S - 1/8x1/4	1/8	10.5	1/4	7	6.01	17	19	7	33	38.5	
S - 1/4x1/4	1/4	13.8	1/4	7	6.01	22	24	7.5	36	42	
S - 1/4x3/8	1/4	13.8	3/8	9	6.35	22	24	7.5	37	42.5	
S - 3/8x3/8	3/8	17.3	3/8	9	6.35	27	32	8	37	43	
S - 3/8x1/2	3/8	17.3	1/2	12	8.16	27	32	8	41	45.5	
S - 1/2x1/2	1/2	21.7	1/2	12	8.16	32	36	9	43	47.5	
S - 1/2x3/4	1/2	21.7	3/4	16	9.53	32	36	9	45	48	
S - 3/4x3/4	3/4	27.2	3/4	16	9.53	41	46	10	48	52.5	
S - 3/4x1	3/4	27.2	1	22	10.39	41	46	10	51	54.5	
S - 1x1	1	34.0	1	22	10.39	46	55	11	52	59	
S - 1x1/4	1	34.0	1/4	28	12.70	46	55	11	55	60	
S - 1 1/4x1 1/4	1 1/4	42.7	1 1/4	31	12.70	60	65	12	64	72	
S - 1 1/4x1 1/2	1 1/4	42.7	1 1/2	34	12.70	60	65	12	64	72	
S - 1 1/2x1 1/2	1 1/2	48.6	1 1/2	36	12.70	65	75	12	67	76	
S - 1 1/2x2	1 1/2	48.6	2	40	15.88	65	75	12	71	76.5	

※Average Values

※上記諸元は品質の向上により若干変わることがあります。

6 くい込み式管継手

ハーフエルボ E

E

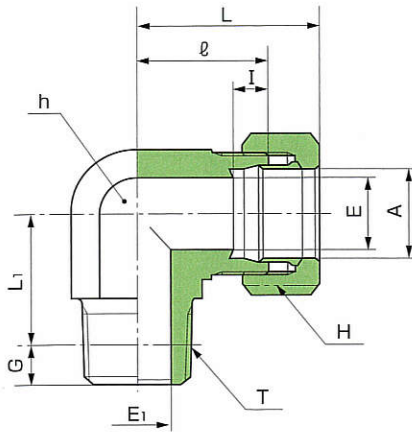

継手の呼び	適用管 呼び径	外径 A	(PT) T	E	E ₁	基準径の 位置 G	二面幅 h	六角対辺 H	I	ℓ	手締め L(約)	(約) L ₁
E-4x1/8	4	4	1/8	2.5	4	3.97	12	12	6	15	22.5	13
E-6x1/8	6	6	1/8	4	4	3.97	14	14	7	20	30.5	14
E-6x1/4	6	6	1/4	4	7	6.01	14	14	7	23	33.5	17
E-8x1/8	8	8	1/8	6	4	3.97	17	17	7	23	33.5	16
E-8x1/4	8	8	1/4	6	7	6.01	17	17	7	23	33.5	18
E-10x1/4	10	10	1/4	8	7	6.01	17	19	7	23	34.5	19
E-10x3/8	10	10	3/8	8	9	6.35	19	19	7	24	35.5	19.5
E-10x1/2	10	10	1/2	8	12	8.16	24	19	7	29	40.5	26
E-12x1/4	12	12	1/4	10	7	6.01	19	22	7	24	35.5	20
E-12x3/8	12	12	3/8	10	9	6.35	19	22	7	24	35.5	20.5
E-12x1/2	12	12	1/2	10	12	8.16	24	22	7	29	40.5	26
E-15x3/8	15	15	3/8	12	9	6.35	24	27	7.5	29	41.5	23.5
E-15x1/2	15	15	1/2	12	12	8.16	24	27	7.5	29	41.5	26
E-16x3/8	16	16	3/8	13	9	6.35	27	30	7.5	32	44.5	25.5
E-16x1/2	16	16	1/2	13	12	8.16	27	30	7.5	32	44.5	27
E-18x3/8	18	18	3/8	14	9	6.35	27	32	8	32	44.5	27.5
E-18x1/2	18	18	1/2	14	12	8.16	27	32	8	32	44.5	30
E-20x1/2	20	20	1/2	17	12	8.16	30	36	8	33	45.5	32
E-20x3/4	20	20	3/4	17	16	9.53	30	36	8	33	45.5	30.5
E-22x1/2	22	22	1/2	18	12	8.16	32	36	9	34	46.5	32
E-22x3/4	22	22	3/4	18	16	9.53	32	36	9	34	46.5	32.5
E-25x3/4	25	25	3/4	20	16	9.53	36	41	10	36	49.5	33.5
E-25x1	25	25	1	20	22	10.39	36	41	10	36	49.5	35.5
E-28x3/4	28	28	3/4	22	16	9.53	41	46	10	41	55	37.5
E-28x1	28	28	1	22	22	10.39	41	46	10	41	55	39.5
E-30x1	30	30	1	25	22	10.39	41	46	10	41	55.5	39.5
E-30x1 1/4	30	30	1 1/4	25	31	12.70	46	46	10	46	60.5	42.5
E-32x1 1/4	32	32	1 1/4	26	31	12.70	46	50	11	46	60.5	43.5
E-35x1 1/4	35	35	1 1/4	28	31	12.70	46	55	11	46	63.5	45.5
E-38x1 1/2	38	38	1 1/2	32	36	12.70	50	60	12	50	69.5	48.5
E-40x1 1/2	40	40	1 1/2	32	36	12.70	55	60	12	55	74.5	49.5
E-42x1 1/2	42	42	1 1/2	34	36	12.70	55	60	12	55	74.5	49.5
E-50x2	50	50	2	40	46	15.88	65	75	12	62	83.5	58
E-1/8x1/8	1/8	10.5	1/8	8	4	3.97	17	19	7	23	34.5	17
E-1/8x1/4	1/8	10.5	1/4	8	7	6.01	17	19	7	23	34.5	19
E-1/4x1/4	1/4	13.8	1/4	11	7	6.01	22	24	7.5	28	40	22
E-1/4x3/8	1/4	13.8	3/8	11	9	6.35	22	24	7.5	28	40	22.5
E-3/8x3/8	3/8	17.3	3/8	14	9	6.35	27	32	8	32	44.5	27.5
E-3/8x1/2	3/8	17.3	1/2	14	12	8.16	27	32	8	32	44.5	30
E-1/2x1/2	1/2	21.7	1/2	18	12	8.16	32	36	9	34	46.5	32
E-1/2x3/4	1/2	21.7	3/4	18	16	9.53	32	36	9	34	46.5	32.5
E-3/4x3/4	3/4	27.2	3/4	22	16	9.53	41	46	10	41	55	37.5
E-3/4x1	3/4	27.2	1	22	22	10.39	41	46	10	41	55	39.5
E-1x1	1	34.0	1	28	22	10.39	46	55	11	46	63.5	44.5
E-1x1 1/4	1	34.0	1 1/4	28	31	12.70	46	55	11	46	63.5	45.5
E-1 1/4x1 1/4	1 1/4	42.7	1 1/4	34	31	12.70	60	65	12	57	77.5	51.5
E-1 1/4x1 1/2	1 1/4	42.7	1 1/2	34	36	12.70	60	65	12	57	77.5	51.5
E-1 1/2x1 1/2	1 1/2	48.6	1 1/2	40	36	12.70	65	75	12	62	83.5	57.5
E-1 1/2x2	1 1/2	48.6	2	40	46	15.88	65	75	12	62	83.5	58

※Average Values

※上記諸元は品質の向上により若干変わることがあります。

ロングハーフエルボ EB

EB

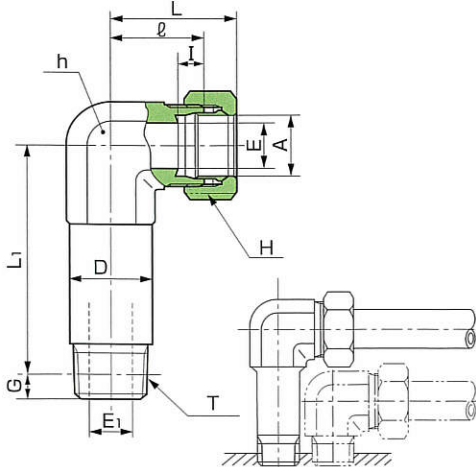

使用例

継手の呼び	適用管 外径A	(PT) T	E	E ₁	基準径の 位置 G	二面幅 h	六角対辺 H	I	D	ℓ	手締め L(約)	(約) L ₁
EB-6x1/8	6	1/8	4	4	3.97	14	14	7	12	20	30.5	36
EB-8x1/4	8	1/4	6	7	6.01	17	17	7	16	23	33.5	43
EB-10x1/4	10	1/4	8	7	6.01	17	19	7	16	23	34.5	46
EB-12x1/4	12	1/4	10	7	6.01	19	22	7	18	24	35.5	52
EB-12x3/8	12	3/8	10	9	6.35	19	22	7	18	24	35.5	53
EB-15x3/8	15	3/8	12	9	6.35	22	27	7.5	23	29	41.5	61.5
EB-15x1/2	15	1/2	12	12	8.16	22	27	7.5	23	29	41.5	67
EB-16x1/2	16	1/2	13	12	8.16	24	30	7.5	24	32	44.5	70
EB-18x1/2	18	1/2	14	12	8.16	27	32	8	26	32	44.5	77
EB-20x3/4	20	3/4	17	16	9.53	30	36	8	28	33	45.5	82.5
EB-22x3/4	22	3/4	18	16	9.53	32	36	9	30	34	46.5	83.5
EB-25x3/4	25	3/4	20	16	9.53	36	41	10	35	36	49.5	90.5
EB-25x1	25	1	20	22	10.39	36	41	10	35	36	49.5	91.5
EB-28x1	28	1	22	22	10.39	41	46	10	40	41	55	104.5
EB-30x1 1/4	30	1 1/4	25	31	12.70	46	46	10	44	46	60.5	104.5
EB-32x1 1/4	32	1 1/4	26	31	12.70	46	50	11	44	46	60.5	104.5
EB-35x1 1/4	35	1 1/4	28	31	12.70	46	55	11	44	46	63.5	121.5

※上記諸元は品質の向上により若干変わることがあります。

※Average Values

メスユニオン (PT)

SA

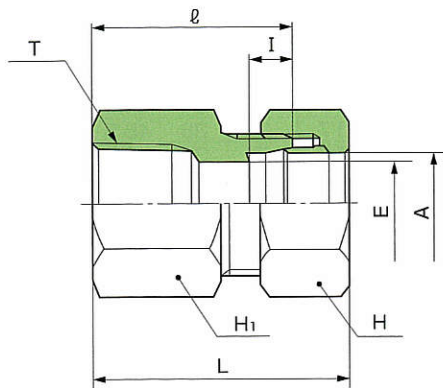

継手の呼び	適用管外径A		(PT) T	E	六角対辺		I	l	手締め L(約)
	呼び径	外径			H ₁	H			
SA - 6×1/8	6	8	1/8	4	17	14	7	25	35.5
SA - 8×1/4	8	10	1/4	6	19	17	7	30	40.5
SA - 10×1/4	10	12	1/4	8	19	19	7	30	41.5
SA - 10×3/8	10	12	3/8	8	24	19	7	32	43.5
SA - 12×1/4	12	15	1/4	10	19	22	7	30	41.5
SA - 12×3/8	12	15	3/8	10	24	22	7	32	43.5
SA - 15×3/8	15	18	3/8	12	24	27	7.5	34	46.5
SA - 15×1/2	15	20	1/2	12	30	27	7.5	39	51.5
SA - 16×1/2	16	22	1/2	13	30	30	7.5	39	51.5
SA - 18×1/2	18	25	1/2	14	30	32	8	39	51.5
SA - 20×3/4	20	28	3/4	17	36	36	8	41	53.5
SA - 22×3/4	22	30	3/4	18	36	36	9	41	53.5
SA - 25×3/4	25	32	3/4	20	36	41	10	41	54.5
SA - 25×1	25	35	1	20	46	41	10	45	58.5
SA - 28×1	28	38	1	22	46	46	10	47	61
SA - 30×1	30	40	1	25	46	46	10	47	61.5
SA - 30×1 1/4	30	42	1 1/4	25	55	46	10	51	65.5
SA - 32×1 1/4	32	45	1 1/4	26	55	50	11	51	65.5
SA - 35×1 1/4	35	48	1 1/4	28	55	55	11	51	68.5
SA - 38×1 1/2	38	50	1 1/2	32	65	60	12	51	70.5
SA - 40×1 1/2	40	52	1 1/2	32	65	60	12	55	74.5
SA - 42×1 1/2	42	54	1 1/2	34	65	60	12	55	74.5
SA - 50×2	50	60	2	40	80	75	12	60	81.5
SA - 1/8×1/4	1/8	10.5	1/4	8	19	19	7	30	41.5
SA - 1/4×3/8	1/4	13.8	3/8	11	24	24	7.5	34	46
SA - 3/8×1/2	3/8	17.3	1/2	14	30	32	8	39	51.5
SA - 1/2×3/4	1/2	21.7	3/4	18	36	36	9	41	53.5
SA - 3/4×1	3/4	27.2	1	22	46	46	10	47	61
SA - 1×1 1/4	1	34.0	1 1/4	28	55	55	11	51	68.5
SA - 1 1/4×1 1/2	1 1/4	42.7	1 1/2	34	65	65	12	55	75.5
SA - 1 1/2×2	1 1/2	48.6	2	40	80	75	12	60	81.5

※Average Values

※上記諸元は品質の向上により若干変わることがあります。

隔壁ハーフユニオン (メス)

JC

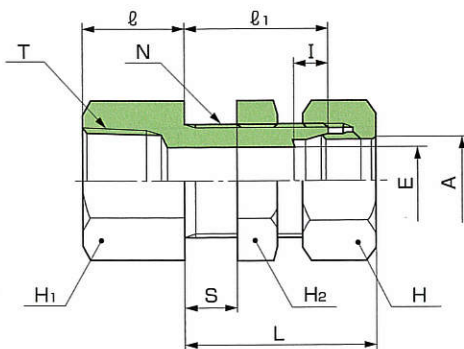

継手の呼び	適用管 外径A	(PT) T	E	六角対辺			I	l ₁	l	手締め L(約)	N	最大 S
				H ₁	H ₂	H						
JC - 6×1/8	6	1/8	4	17	17	14	7	32	13	42.5	M12×1.5	13
JC - 8×1/4	8	1/4	6	19	19	17	7	32	18	42.5	M14×1.5	13
JC - 10×1/4	10	1/4	8	19	22	19	7	32	18	43.5	M16×1.5	13
JC - 10×3/8	10	3/8	8	24	22	19	7	32	20	43.5	M16×1.5	13
JC - 12×1/4	12	1/4	10	19	24	22	7	32	18	43.5	M18×1.5	13
JC - 12×3/8	12	3/8	10	24	24	22	7	32	20	43.5	M18×1.5	13
JC - 15×3/8	15	3/8	12	24	27	27	7.5	37	20	49.5	M22×1.5	15
JC - 15×1/2	15	1/2	12	30	27	27	7.5	37	25	49.5	M22×1.5	15
JC - 16×1/2	16	1/2	13	30	30	30	7.5	37	25	49.5	M24×1.5	15
JC - 18×1/2	18	1/2	14	30	32	32	8	39	25	51.5	M26×1.5	15
JC - 20×3/4	20	3/4	17	36	32	36	8	39	27	51.5	M28×1.5	15
JC - 22×3/4	22	3/4	18	36	36	36	9	39	27	51.5	M30×1.5	15
JC - 25×3/4	25	3/4	20	41	41	41	10	39	27	52.5	M35×1.5	15
JC - 25×1	25	1	20	46	41	41	10	39	31	52.5	M35×1.5	15
JC - 28×1	28	1	22	46	46	46	10	41	31	55	M38×1.5	15
JC - 30×1	30	1	25	46	46	46	10	41	31	55.5	M40×1.5	15
JC - 30×1 1/4	30	1 1/4	25	55	46	46	10	41	35	55.5	M40×1.5	15
JC - 32×1 1/4	32	1 1/4	26	55	46	50	11	43	35	57.5	M42×1.5	15

※Average Values

※上記諸元は品質の向上により若干変わることがあります。

3 くい込み式管継手

ロングハーフユニオン SB

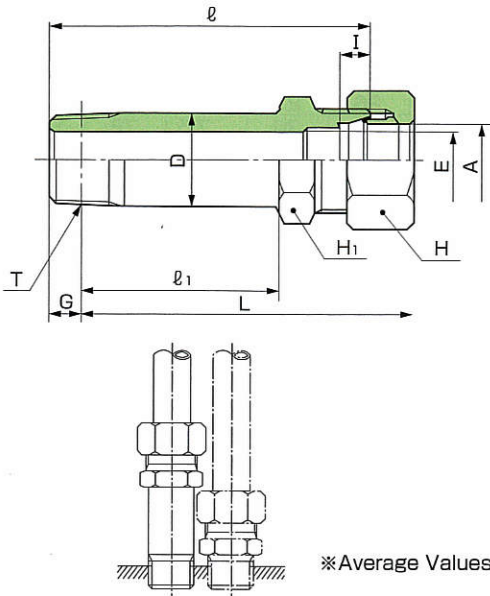

※Average Values

使用例

継手の呼び	適用管外径A		(PT) T	E	基準径 の位置 G	六角対辺		I	D	ℓ	ℓ ₁	手じめ L(約)
	呼び径	外径				H ₁	H					
SB - 4×1/8	4	1/8	2.5	3.97	12	12	6	10.5	46	30	49.5	
SB - 6×1/8	6	1/8	4	3.97	14	14	7	10.5	63	41	69.5	
SB - 8×1/4	8	1/4	6	6.01	17	17	7	14	70	45	74.5	
SB - 10×1/4	10	1/4	7	6.01	17	19	7	14	71	46	76.5	
SB - 10×3/8	10	3/8	8	6.35	19	19	7	17.5	72	46.5	77	
SB - 12×1/4	12	1/4	7	6.01	19	22	7	14	71	46	76.5	
SB - 12×3/8	12	3/8	9	6.35	19	22	7	17.5	72	46.5	77	
SB - 15×3/8	15	3/8	9	6.35	24	27	7.5	17.5	81	52.5	87	
SB - 15×1/2	15	1/2	12	8.16	24	27	7.5	22	86	56	90.5	
SB - 16×1/2	16	1/2	12	8.16	27	30	7.5	22	86	56	90.5	
SB - 18×1/2	18	1/2	12	8.16	27	32	8	22	86	56	90.5	
SB - 20×3/4	20	3/4	16	9.53	30	36	8	27.5	92	58.5	95	
SB - 22×3/4	22	3/4	16	9.53	32	36	9	27.5	93	59.5	96	
SB - 25×1	25	1	20	10.39	36	41	10	34	99	63.5	102	
SB - 28×1	28	1	22	10.39	41	46	10	34	104	66.5	107.5	
SB - 30×1 1/4	30	1 1/4	25	12.70	46	46	10	42.5	109	68.5	111	
SB - 32×1 1/4	32	1 1/4	26	12.70	46	50	11	42.5	110	69.5	112	
SB - 1/8×1/4	1/8	10.5	1/4	7	6.01	17	19	7	14	71	46	76.5
SB - 1/4×3/8	1/4	13.8	3/8	9	6.35	22	24	7.5	17.5	81	52.5	86.5
SB - 3/8×3/8	3/8	17.3	3/8	9	6.35	27	32	8	17.5	81	52.5	87
SB - 3/8×1/2	3/8	17.3	1/2	12	8.16	27	32	8	22	86	56	90.5
SB - 1/2×3/4	1/2	21.7	3/4	16	9.53	32	36	9	27.5	93	59.5	96
SB - 3/4×1	3/4	27.2	1	22	10.39	41	46	10	34	104	66.5	107.5

※上記諸元は品質の向上により若干変わることがあります。

ハーフユニオン (PF) SO

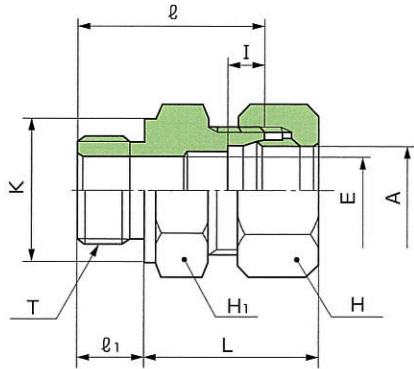

※Average Values

継手の呼び	適用管外径A		(PF) T	E	六角対辺		I	K	ℓ ₁	ℓ	手じめ L(約)
	呼び径	外径			H ₁	H					
SO - 4×1/8	4	1/8	2.5	14	12	6	14	8	23	22.5	
SO - 6×1/8	6	1/8	4	14	14	7	14	8	28	30.5	
SO - 6×1/4	6	1/4	4	19	14	7	19	12	33	31.5	
SO - 8×1/8	8	1/8	4	17	17	7	14	8	28	30.5	
SO - 8×1/4	8	1/4	6	19	17	7	19	12	33	31.5	
SO - 10×1/4	10	1/4	6	19	19	7	19	12	33	32.5	
SO - 10×3/8	10	3/8	8	22	19	7	22	12	34	33.5	
SO - 12×1/4	12	1/4	6	19	22	7	19	12	33	32.5	
SO - 12×3/8	12	3/8	8	22	22	7	22	12	34	33.5	
SO - 12×1/2	12	1/2	10	27	22	7	27	14	39	36.5	
SO - 15×3/8	15	3/8	8	24	27	7.5	22	12	37	37.5	
SO - 15×1/2	15	1/2	12	27	27	7.5	27	14	41	39.5	
SO - 16×1/2	16	1/2	12	27	30	7.5	27	14	41	39.5	
SO - 18×1/2	18	1/2	12	27	32	8	27	14	41	39.5	
SO - 20×3/4	20	3/4	16	36	36	8	36	16	46	42.5	
SO - 22×1/2	22	1/2	12	32	36	9	27	14	43	41.5	
SO - 22×3/4	22	3/4	16	36	36	9	36	16	46	42.5	
SO - 25×3/4	25	3/4	16	36	41	10	36	16	46	43.5	
SO - 25×1	25	1	20	41	41	10	41	18	50	45.5	
SO - 28×1	28	1	22	41	46	10	41	18	52	48	
SO - 30×1	30	1	22	41	46	10	41	18	52	48.5	
SO - 30×1 1/4	30	1 1/4	25	50	46	10	50	20	57	51.5	
SO - 32×1 1/4	32	1 1/4	26	50	50	11	50	20	57	51.5	
SO - 35×1 1/4	35	1 1/4	28	50	55	11	50	20	57	54.5	
SO - 38×1 1/2	38	1 1/2	32	55	60	12	55	21	58	56.5	
SO - 40×1 1/2	40	1 1/2	32	55	60	12	55	21	62	60.5	
SO - 42×1 1/2	42	1 1/2	34	55	60	12	55	21	62	60.5	
SO - 50×2	50	2	40	75	75	12	75	25	73	69.5	
SO - 1/8×1/8	1/8	10.5	1/8	4	17	19	7	14	8	29	32.5
SO - 1/8×1/4	1/8	10.5	1/4	6	19	19	7	19	12	33	32.5
SO - 1/4×1/4	1/4	13.8	1/4	6	22	24	7.5	19	12	36	36
SO - 1/4×3/8	1/4	13.8	3/8	8	22	24	7.5	22	12	36	36
SO - 3/8×3/8	3/8	17.3	3/8	8	27	32	8	22	12	38	38.5
SO - 3/8×1/2	3/8	17.3	1/2	12	27	32	8	27	14	41	39.5
SO - 1/2×1/2	1/2	21.7	1/2	12	32	36	9	27	14	43	41.5
SO - 1/2×3/4	1/2	21.7	3/4	16	36	36	9	36	16	46	42.5
SO - 3/4×3/4	3/4	27.2	3/4	16	41	46	10	36	16	50	48
SO - 3/4×1	3/4	27.2	1	22	41	46	10	41	18	52	48
SO - 1×1	1	34.0	1	22	46	55	11	41	18	54	53.5
SO - 1×1 1/4	1	34.0	1 1/4	28	50	55	11	50	20	57	54.5
SO - 1 1/4×1 1/4	1 1/4	42.7	1 1/4	31	60	65	12	50	20	63	63.5
SO - 1 1/4×1 1/2	1 1/4	42.7	1 1/2	34	60	65	12	55	21	64	63.5
SO - 1 1/2×1 1/2	1 1/2	48.6	1 1/2	36	65	75	12	55	21	65	63.5
SO - 1 1/2×2	1 1/2	48.6	2	40	75	75	12	75	25	73	69.5

注：1. 対応するパッキンはOリング、ボンデッドシールが使用できます。
 ※上記諸元は品質の向上により若干変わることがあります。

9 くい込み式管継手

両口チース (オス) F

F

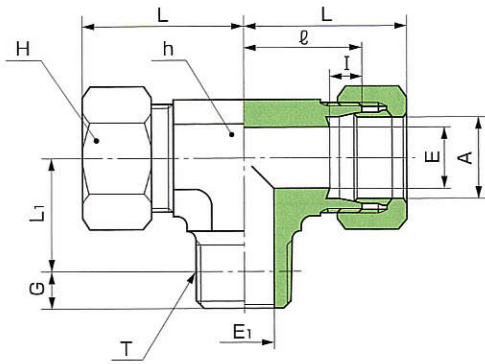

継手の呼び	適用管外径A 呼び径 外径	(PT) T	E	E ₁	基準径の 位置 G	二面幅 h	六角対辺 H	I	ℓ	手締め L (約)	(約) L ₁	
F- 4×1/8	4	1/8	2.5	4	3.97	12	12	6	15	22.5	13	
F- 6×1/8	6	1/8	4	4	3.97	14	14	7	20	30.5	14	
F- 6×1/4	6	1/4	4	7	6.01	17	14	7	23	33.5	17	
F- 8×1/8	8	1/8	6	4	3.97	17	17	7	23	33.5	16	
F- 8×1/4	8	1/4	6	7	6.01	17	17	7	23	33.5	18	
F- 10×1/4	10	1/4	8	7	6.01	17	19	7	23	34.5	19	
F- 10×3/8	10	3/8	8	9	6.35	19	19	7	24	35.5	19.5	
F- 12×1/4	12	1/4	10	7	6.01	19	22	7	24	35.5	18	
F- 12×3/8	12	3/8	10	9	6.35	19	22	7	24	35.5	20.5	
F- 15×3/8	15	3/8	12	9	6.35	24	27	7.5	29	41.5	23.5	
F- 15×1/2	15	1/2	12	12	8.16	24	27	7.5	29	41.5	26	
F- 16×1/2	16	1/2	13	12	8.16	27	30	7.5	32	44.5	27	
F- 18×1/2	18	1/2	14	12	8.16	27	32	8	32	44.5	30	
F- 20×3/4	20	3/4	17	16	9.53	30	36	8	33	45.5	30.5	
F- 22×3/4	22	3/4	18	16	9.53	32	36	9	34	46.5	32.5	
F- 25×3/4	25	3/4	20	16	9.53	36	41	10	36	49.5	33.5	
F- 25×1	25	1	20	22	10.39	36	41	10	36	49.5	35.5	
F- 28×1	28	1	22	22	10.39	41	46	10	41	55	39.5	
F- 30×1	30	1	25	22	10.39	41	46	10	41	55.5	39.5	
F- 30×1 1/4	30	1 1/4	25	31	12.70	46	46	10	46	60.5	42.5	
F- 32×1 1/4	32	1 1/4	26	31	12.70	46	50	11	46	60.5	43.5	
F- 35×1 1/4	35	1 1/4	28	31	12.70	46	55	11	46	63.5	45.5	
F- 38×1 1/2	38	1 1/2	32	36	12.70	50	60	12	50	69.5	48.5	
F- 40×1 1/2	40	1 1/2	32	36	12.70	55	60	12	55	74.5	49.5	
F- 50×2	50	2	40	46	15.88	65	75	12	62	83.5	58	
F- 1/8×1/4	1/8	10.5	1/4	8	7	6.01	17	19	7	23	34.5	19
F- 1/4×3/8	1/4	13.8	3/8	11	9	6.35	22	24	7.5	28	40	22.5
F- 3/8×1/2	3/8	17.3	1/2	14	12	8.16	27	32	8	32	44.5	30
F- 1/2×3/4	1/2	21.7	3/4	18	16	9.53	32	36	9	34	46.5	32.5
F- 3/4×1	3/4	27.2	1	22	22	10.39	41	46	10	41	55	39.5
F- 1×1 1/4	1	34.0	1 1/4	28	31	12.70	46	55	11	46	63.5	45.5
F- 1 1/4×1 1/2	1 1/4	42.7	1 1/2	34	36	12.70	60	65	12	57	77.5	51.5
F- 1 1/2×2	1 1/2	48.6	2	40	46	15.88	65	75	12	62	83.5	58

※Average Values

※上記諸元は品質の向上により若干変わることがあります。

サービスチース (メス) FB

FB

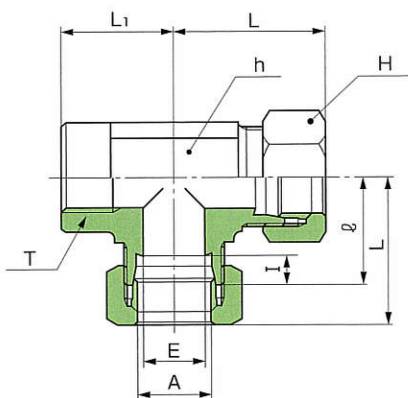

継手の呼び	適用管外径A 呼び径 外径	(PT) T	E	二面幅 h	六角対辺 H	I	ℓ	手締め L (約)	L ₁	
FB- 8×1/4	8	1/4	6	19	17	7	24	34.5	24	
FB- 10×1/4	10	1/4	8	19	19	7	24	35.5	24	
FB- 12×1/4	12	1/4	10	19	22	7	24	35.5	24	
FB- 12×3/8	12	3/8	10	24	22	7	29	40.5	29	
FB- 15×3/8	15	3/8	12	24	27	7.5	29	41.5	29	
FB- 15×1/2	15	1/2	12	30	27	7.5	33	45.5	33	
FB- 16×1/2	16	1/2	13	30	30	7.5	33	45.5	33	
FB- 18×1/2	18	1/2	14	30	32	8	33	45.5	33	
FB- 20×3/4	20	3/4	17	36	36	8	36	48.5	36	
FB- 22×3/4	22	3/4	18	36	36	9	36	48.5	36	
FB- 25×3/4	25	3/4	20	36	41	10	36	49.5	36	
FB- 25×1	25	1	20	46	41	10	46	59.5	46	
FB- 28×1	28	1	22	46	46	10	46	60	46	
FB- 30×1	30	1	25	46	46	10	46	60.5	46	
FB- 30×1 1/4	30	1 1/4	25	55	46	10	55	69.5	55	
FB- 32×1 1/4	32	1 1/4	26	55	50	11	55	69.5	55	
FB- 35×1 1/4	35	1 1/4	28	55	55	11	55	72.5	55	
FB- 1/8×1/4	1/8	10.5	1/4	8	19	19	7	24	35.5	24
FB- 1/4×3/8	1/4	13.8	3/8	11	24	24	7.5	29	41	29
FB- 3/8×1/2	3/8	17.3	1/2	14	30	32	8	33	45.5	33
FB- 1/2×3/4	1/2	21.7	3/4	18	36	36	9	36	48.5	36
FB- 3/4×1	3/4	27.2	1	22	46	46	10	46	60	46
FB- 1×1 1/4	1	34.0	1 1/4	28	55	55	11	55	72.5	55

※Average Values

※上記諸元は品質の向上により若干変わることがあります。

8 くい込み式管継手

ユニオンチース

T

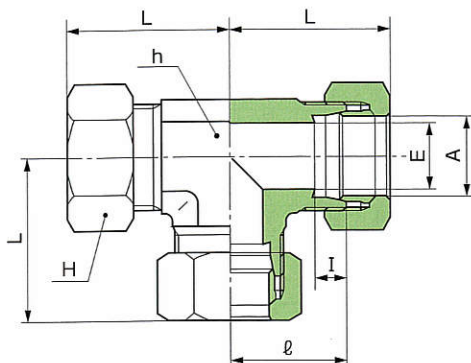

継手の呼び	適用管外径A		E	二面幅 h	六角対辺 H	I	ℓ	手締め L(約)
	呼び径	外径						
T-4	4	4	2.5	12	12	6	15	22.5
T-6	6	6	4	14	14	7	20	30.5
T-8	8	8	6	17	17	7	23	33.5
T-10	10	10	8	17	19	7	23	34.5
T-12	12	12	10	19	22	7	24	35.5
T-15	15	15	12	24	27	7.5	29	41.5
T-16	16	16	13	27	30	7.5	32	44.5
T-18	18	18	14	27	32	8	32	44.5
T-20	20	20	17	30	36	8	33	45.5
T-22	22	22	18	32	36	9	34	46.5
T-25	25	25	20	36	41	10	36	49.5
T-28	28	28	22	41	46	10	41	55.0
T-30	30	30	25	41	46	10	41	55.5
T-32	32	32	26	46	50	11	45	59.5
T-35	35	35	28	46	55	11	46	63.5
T-38	38	38	32	50	60	12	50	69.5
T-40	40	40	32	55	60	12	55	74.5
T-42	42	42	34	55	60	12	55	74.5
T-50	50	50	40	65	75	12	62	83.5
T-1/8	1/8	10.5	8	17	19	7	23	34.5
T-1/4	1/4	13.8	11	22	24	7.5	28	40.0
T-3/8	3/8	17.3	14	27	32	8	32	44.5
T-1/2	1/2	21.7	18	32	36	9	34	46.5
T-3/4	3/4	27.2	22	41	46	10	41	55.0
T-1	1	34.0	28	46	55	11	46	63.5
T-1 1/4	1 1/4	42.7	34	60	65	12	57	77.5
T-1 1/2	1 1/2	48.6	40	65	75	12	62	83.5

※Average Values

※上記諸元は品質の向上により若干変わることがあります。

サービスチース(オス)

FC

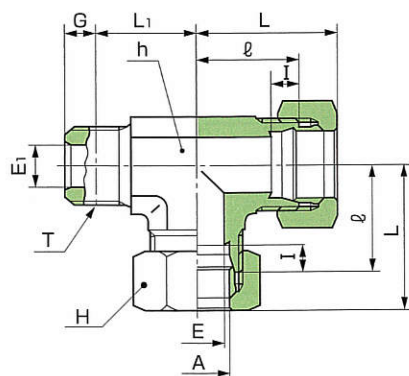

継手の呼び	適用管外径A		(PT) T	E	E1	基準径の 位置 G	二面幅 h	六角対辺 H	I	ℓ	手締め L(約)	(約) L1
	呼び径	外径										
FC-4x1/8	4	1/8	2.5	4	3.97	12	12	6	15	22.5	13	
FC-6x1/8	6	1/8	4	4	3.97	14	14	7	20	30.5	14	
FC-6x1/4	6	1/4	4	7	6.01	17	14	7	23	33.5	17	
FC-8x1/8	8	1/8	6	4	3.97	17	17	7	23	33.5	16	
FC-8x1/4	8	1/4	6	7	6.01	17	17	7	23	33.5	18	
FC-10x1/4	10	1/4	8	7	6.01	17	19	7	23	34.5	19	
FC-10x3/8	10	3/8	8	9	6.35	19	19	7	24	35.5	19.5	
FC-12x1/4	12	1/4	10	7	6.01	19	22	7	24	35.5	18	
FC-12x3/8	12	3/8	10	9	6.35	19	22	7	24	35.5	20.5	
FC-15x3/8	15	3/8	12	9	6.35	24	27	7.5	29	41.5	23.5	
FC-15x1/2	15	1/2	12	12	8.16	24	27	7.5	29	41.5	26	
FC-16x1/2	16	1/2	13	12	8.16	27	30	7.5	32	44.5	27	
FC-18x1/2	18	1/2	14	12	8.16	27	32	8	32	44.5	30	
FC-20x3/4	20	3/4	17	16	9.53	30	36	8	33	45.5	30.5	
FC-22x3/4	22	3/4	18	16	9.53	32	36	9	34	46.5	32.5	
FC-25x3/4	25	3/4	20	16	9.53	36	41	10	36	49.5	33.5	
FC-25x1	25	1	20	22	10.39	36	41	10	36	49.5	35.5	
FC-28x1	28	1	22	22	10.39	41	46	10	41	55	39.5	
FC-30x1	30	1	25	22	10.39	41	46	10	41	55.5	39.5	
FC-30x1 1/4	30	1 1/4	25	31	12.70	46	46	10	46	60.5	42.5	
FC-32x1 1/4	32	1 1/4	26	31	12.70	46	50	11	46	60.5	43.5	
FC-35x1 1/4	35	1 1/4	28	31	12.70	46	55	11	46	63.5	45.5	
FC-38x1 1/2	38	1 1/2	32	36	12.70	50	60	12	50	69.5	48.5	
FC-40x1 1/2	40	1 1/2	32	36	12.70	55	60	12	55	74.5	49.5	
FC-50x2	50	2	40	46	15.88	65	75	12	62	83.5	58	
FC-1/8x1/4	1/8	10.5	1/4	8	7	6.01	17	19	7	23	34.5	19
FC-1/4x3/8	1/4	13.8	3/8	11	9	6.35	22	24	7.5	28	40	22.5
FC-3/8x1/2	3/8	17.3	1/2	14	12	8.16	27	32	8	32	44.5	30
FC-1/2x3/4	1/2	21.7	3/4	18	16	9.53	32	36	9	34	46.5	32.5
FC-3/4x1	3/4	27.2	1	22	22	10.39	41	46	10	41	55	39.5
FC-1x1 1/4	1	34.0	1 1/4	28	31	12.70	46	55	11	46	63.5	45.5
FC-1 1/4x1 1/2	1 1/4	42.7	1 1/2	34	36	12.70	60	65	12	57	77.5	51.5
FC-1 1/2x2	1 1/2	48.6	2	40	46	15.88	65	75	12	62	83.5	58

※Average Values

※上記諸元は品質の向上により若干変わることがあります。

10 くい込み式管継手

両口チース(メス)

FA

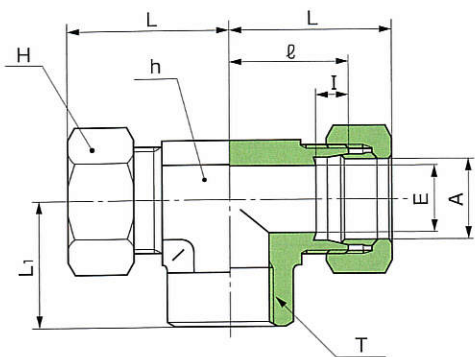

継手の呼び	適用管外径A		(PT) T	E	二面幅 h	六角対辺 H		I	φ	手締め L(約)	L ₁
	呼び径	外径									
FA - 8×1/4	8		1/4	6	19	17	7	24	34.5	24	
FA - 10×1/4	10		1/4	8	19	19	7	24	35.5	24	
FA - 12×1/4	12		1/4	10	19	22	7	24	35.5	24	
FA - 12×3/8	12		3/8	10	24	22	7	29	40.5	29	
FA - 15×3/8	15		3/8	12	24	27	7.5	29	41.5	29	
FA - 15×1/2	15		1/2	12	30	27	7.5	33	45.5	33	
FA - 16×1/2	16		1/2	13	30	30	7.5	33	45.5	33	
FA - 18×1/2	18		1/2	14	30	32	8	33	45.5	33	
FA - 20×3/4	20		3/4	17	36	36	8	36	48.5	36	
FA - 22×3/4	22		3/4	18	36	36	9	36	48.5	36	
FA - 25×3/4	25		3/4	20	36	41	10	36	49.5	36	
FA - 25×1	25		1	20	46	41	10	46	59.5	46	
FA - 28×1	28		1	22	46	46	10	46	60	46	
FA - 30×1	30		1	25	46	46	10	46	60.5	46	
FA - 30×1 1/4	30		1 1/4	25	55	46	10	55	69.5	55	
FA - 32×1 1/4	32		1 1/4	26	55	50	11	55	69.5	55	
FA - 35×1 1/4	35		1 1/4	28	55	55	11	55	72.5	55	
FA - 1/8×1/4	1/8	10.5	1/4	8	19	19	7	24	35.5	24	
FA - 1/4×3/8	1/4	13.8	3/8	11	24	24	7.5	29	41	29	
FA - 3/8×1/2	3/8	17.3	1/2	14	30	32	8	33	45.5	33	
FA - 1/2×3/4	1/2	21.7	3/4	18	36	36	9	36	48.5	36	
FA - 3/4×1	3/4	27.2	1	22	46	46	10	46	60	46	
FA - 1×1 1/4	1	34.0	1 1/4	28	55	55	11	55	72.5	55	

※Average Values

※上記諸元は品質の向上により若干変わることがあります。

レジャーサー

R

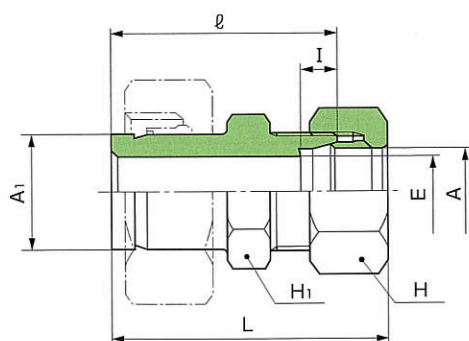

使用例

継手の呼び	対応する 継手の呼び	A ₁	適用管外径A		E	六角対辺 H ₁ H		I	φ	手締め L(約)
			呼び径	外径						
R - 8×6	8	8		6	4	14	14	7	39	49.5
R - 10×6	10	10		6	4	14	14	7	40	50.5
R - 10×8	10	10		8	6	17	17	7	40	50.5
R - 12×6	12	12		6	4	14	14	7	41	51.5
R - 12×8	12	12		8	6	17	17	7	41	51.5
R - 12×10	12	12		10	8	17	19	7	41	52.5
R - 15×8	15	15		8	6	17	17	7	43	53.5
R - 15×10	15	15		10	8	17	19	7	43	54.5
R - 16×6	16	16		6	4	17	14	7	43	53.5
R - 16×10	16	16		10	8	17	19	7	43	54.5
R - 16×12	16	16		12	10	19	22	7	43	54.5
R - 18×10	18	18		10	8	19	19	7	44	55.5
R - 18×15	18	18		15	12	24	27	7.5	45	57.5
R - 20×6	20	20		6	4	22	14	7	45	55.5
R - 20×12	20	20		12	10	22	22	7	45	56.5
R - 20×16	20	20		16	13	27	30	7.5	47	59.5
R - 22×15	22	22		15	12	24	27	7.5	48	60.5
R - 22×18	22	22		18	14	27	32	8	48	60.5
R - 25×16	25	25		16	13	27	30	7.5	50	62.5
R - 25×20	25	25		20	17	30	36	8	52	64.5
R - 28×18	28	28		18	14	30	32	8	52	64.5
R - 28×22	28	28		22	18	32	36	9	52	64.5
R - 30×20	30	30		20	17	32	36	8	53	65.5
R - 30×25	30	30		25	20	36	41	10	54	67.5
R - 32×25	32	32		25	20	36	41	10	55	68.5
R - 35×22	35	35		22	18	36	36	9	58	70.5
R - 35×28	35	35		28	22	36	46	10	60	74
R - 38×25	38	38		25	20	41	41	10	61	74.5
R - 38×30	38	38		30	25	41	46	10	63	77.5
R - 1/4×1/8	13(1/4)	13.8	1/8	10.5	8	17	19	7	41	52.5
R - 3/8×1/8	17(3/8)	17.3	1/8	10.5	8	19	19	7	44	55.5
R - 3/8×1/4	17(3/8)	17.3	1/4	13.8	11	22	24	7.5	46	58
R - 1/2×1/4	21(1/2)	21.7	1/4	13.8	11	24	24	7.5	48	60
R - 1/2×3/8	21(1/2)	21.7	3/8	17.3	14	27	32	8	48	60.5
R - 3/4×3/8	27(3/4)	27.2	3/8	17.3	14	30	32	8	52	64.5
R - 3/4×1/2	27(3/4)	27.2	1/2	21.7	18	32	36	9	52	64.5
R - 1×1/2	34(1)	34.0	1/2	21.7	18	36	36	9	58	70.5
R - 1×3/4	34(1)	34.0	3/4	27.2	22	41	46	10	60	74

※Average Values

※上記諸元は品質の向上により若干変わることがあります。

ハーフニップル

EN

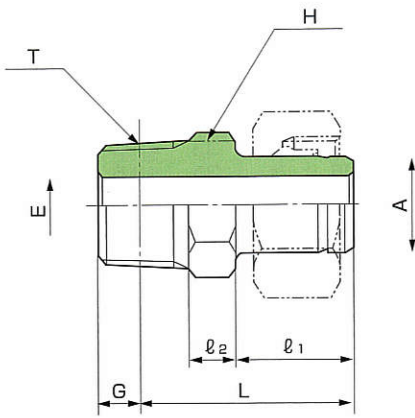

継手の呼び	適用管外径A		(PT) T	E	基準径の位置 G	六角対辺 H	l ₁	l ₂	(約) L
	呼び径	外径							
EN - 6×1/8	6	6	1/8	3	3.97	12	20	6	32
EN - 8×1/4	8	8	1/4	5	6.01	14	20	7	35
EN - 10×1/4	10	10	1/4	6	6.01	14	21	7	36
EN - 10×3/8	10	10	3/8	6	6.35	19	21	7	36.5
EN - 12×1/4	12	12	1/4	7	6.01	14	22	7	37
EN - 12×3/8	12	12	3/8	8	6.35	19	22	7	37.5
EN - 15×3/8	15	15	3/8	8	6.35	19	24	8	40.5
EN - 15×1/2	15	15	1/2	10	8.16	22	24	8	43
EN - 16×1/2	16	16	1/2	11	8.16	22	24	8	43
EN - 18×1/2	18	18	1/2	12	8.16	22	24	8	43
EN - 20×3/4	20	20	3/4	14	9.53	27	25	10	46.5
EN - 22×3/4	22	22	3/4	14	9.53	27	26	10	47.5
EN - 25×3/4	25	25	3/4	16	9.53	27	28	10	49.5
EN - 25×1	25	25	1	17	10.39	36	28	11	52.5
EN - 28×1	28	28	1	18	10.39	36	28	11	52.5
EN - 30×1	30	30	1	20	10.39	36	29	11	53.5
EN - 30×1 1/4	30	30	1 1/4	20	12.70	46	29	12	55
EN - 32×1 1/4	32	32	1 1/4	22	12.70	46	30	12	56
EN - 38×1 1/2	38	38	1 1/2	26	12.70	50	36	14	64.5
EN - 40×1 1/2	40	40	1 1/2	28	12.70	50	36	14	64
EN - 50×2	50	50	2	34	15.88	65	37	20	72
EN - 1/8×1/4	1/8	10.5	1/4	6	6.01	14	21	7	36
EN - 1/4×3/8	1/4	13.8	3/8	9	6.35	19	22	8	38.5
EN - 3/8×1/2	3/8	17.3	1/2	11	8.16	22	24	8	43
EN - 1/2×3/4	1/2	21.7	3/4	14	9.53	27	26	10	47.5
EN - 3/4×1	3/4	27.2	1	18	10.39	36	28	11	52.5
EN - 1×1 1/4	1	34.0	1 1/4	23	12.70	46	33	12	59
EN - 1 1/4×1 1/2	1 1/4	42.7	1 1/2	29	12.70	50	36	17	67
EN - 1 1/2×2	1 1/2	48.6	2	33	15.88	65	37	20	72

※Average Values

※上記諸元は品質の向上により若干変わることがあります。

ハーフニップル (PF)

EN₂

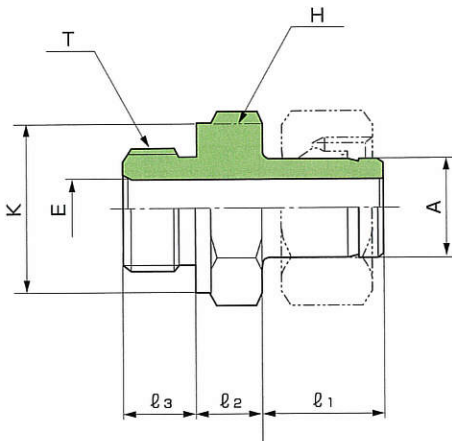

継手の呼び	適用管外径A		(PF) T	E	六角対辺 H	K	l ₁	l ₂	l ₃
	呼び径	外径							
EN ₂ - 6×1/8	6	6	1/8	3	14	14	20	8	8
EN ₂ - 8×1/4	8	8	1/4	5	19	19	20	9	12
EN ₂ - 10×1/4	10	10	1/4	6	19	19	21	9	12
EN ₂ - 10×3/8	10	10	3/8	6	22	22	21	10	12
EN ₂ - 12×1/4	12	12	1/4	7	19	19	22	9	12
EN ₂ - 12×3/8	12	12	3/8	8	22	22	22	10	12
EN ₂ - 15×3/8	15	15	3/8	8	22	22	24	10	12
EN ₂ - 15×1/2	15	15	1/2	10	27	27	24	13	14
EN ₂ - 16×1/2	16	16	1/2	11	27	27	24	13	14
EN ₂ - 18×1/2	18	18	1/2	12	27	27	24	13	14
EN ₂ - 20×3/4	20	20	3/4	14	36	36	25	16	16
EN ₂ - 22×3/4	22	22	3/4	14	36	36	26	16	16
EN ₂ - 25×3/4	25	25	3/4	16	36	36	28	16	16
EN ₂ - 25×1	25	25	1	17	41	41	28	18	18
EN ₂ - 28×1	28	28	1	18	41	41	28	18	18
EN ₂ - 30×1	30	30	1	20	41	41	29	21	18
EN ₂ - 30×1 1/4	30	30	1 1/4	20	50	50	29	21	20
EN ₂ - 32×1 1/4	32	32	1 1/4	22	50	50	30	21	20
EN ₂ - 38×1 1/2	38	38	1 1/2	26	55	55	36	21	21
EN ₂ - 40×1 1/2	40	40	1 1/2	28	55	55	36	21	21
EN ₂ - 50×2	50	50	2	34	75	75	37	28	24
EN ₂ - 1/8×1/4	1/8	10.5	1/4	6	19	19	21	9	12
EN ₂ - 1/4×3/8	1/4	13.8	3/8	9	22	22	22	10	12
EN ₂ - 3/8×1/2	3/8	17.3	1/2	11	27	27	24	13	14
EN ₂ - 1/2×3/4	1/2	21.7	3/4	14	36	36	26	16	16
EN ₂ - 3/4×1	3/4	27.2	1	18	41	41	28	18	18
EN ₂ - 1×1 1/4	1	34.0	1 1/4	23	50	50	33	21	20
EN ₂ - 1 1/4×1 1/2	1 1/4	42.7	1 1/2	29	55	55	36	23	21
EN ₂ - 1 1/2×2	1 1/2	48.6	2	33	75	75	37	28	24

※Average Values

※上記諸元は品質の向上により若干変わることがあります。

圧力計ユニオン (PF) A₂

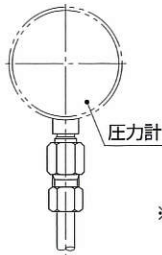
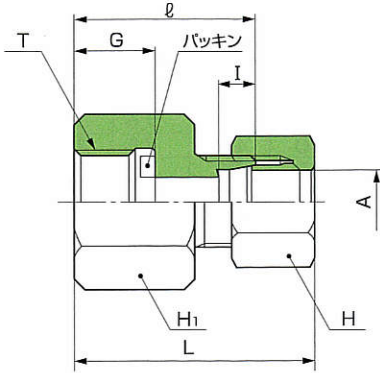

使用例

※Average Values

継手の呼び	適用管 外径A	(PF) T	G	六角対辺		I	l	手締め L(約)	パッキン
				H ₁	H				
A ₂ - 4×1/4	4	1/4	14	19	12	6	29	36.5	1/4
A ₂ - 4×3/8	4	3/8	15	24	12	6	30	37.5	3/8
A ₂ - 6×1/4	6	1/4	14	19	14	7	32	42.5	1/4
A ₂ - 6×3/8	6	3/8	15	24	14	7	34	44.5	3/8
A ₂ - 6×1/2	6	1/2	16	30	14	7	36	46.5	1/2
A ₂ - 8×1/4	8	1/4	14	19	17	7	32	42.5	1/4
A ₂ - 8×3/8	8	3/8	15	24	17	7	34	44.5	3/8
A ₂ - 8×1/2	8	1/2	16	30	17	7	36	46.5	1/2
A ₂ - 10×1/4	10	1/4	14	19	19	7	32	43.5	1/4
A ₂ - 10×3/8	10	3/8	15	24	19	7	34	45.5	3/8
A ₂ - 10×1/2	10	1/2	16	30	19	7	36	47.5	1/2
A ₂ - 12×1/4	12	1/4	14	19	22	7	32	43.5	1/4
A ₂ - 12×3/8	12	3/8	15	24	22	7	34	45.5	3/8
A ₂ - 12×1/2	12	1/2	16	30	22	7	36	47.5	1/2

パッキンは標準付属いたしませんので必要の場合はその旨ご指示下さい。
なお、この場合当社の標準パッキンの寸法および材質は下記の通りです。

パッキンの呼び	パッキンの寸法		
	d	D	t
1/4	6	11	2
3/8	6	14	2
1/2	6	18	2

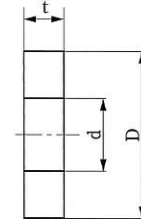

※上記諸元は品質の向上により若干変わることがあります。

溶接ハーフユニオン NW

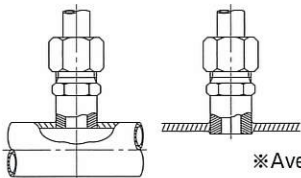
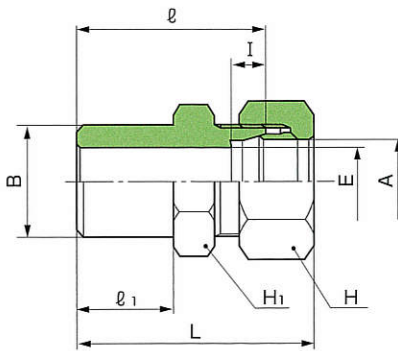

使用例

※Average Values

継手の呼び	適用管外径A		B	E	六角対辺		I	l ₁	l	手締め L(約)
	呼び	径			H ₁	H				
NW - 6	6	6	12	4	14	14	7	11	29	39.5
NW - 8	8	8	14	6	17	17	7	15	34	44.5
NW - 10	10	10	16	8	17	19	7	15	34	45.5
NW - 12	12	12	18	10	19	22	7	15	34	45.5
NW - 15	15	15	21	12	24	27	7.5	18	40	52.5
NW - 16	16	16	22	13	27	30	7.5	22	44	56.5
NW - 18	18	18	25	14	27	32	8	22	44	56.5
NW - 20	20	20	28	17	30	36	8	22	46	58.5
NW - 22	22	22	28	18	32	36	9	22	46	58.5
NW - 25	25	25	33	20	36	41	10	26	51	64.5
NW - 28	28	28	36	22	41	46	10	28	55	69
NW - 30	30	30	39	25	41	46	10	28	55	69.5
NW - 32	32	32	40	26	46	50	11	28	56	70.5
NW - 35	35	35	43	28	46	55	11	28	56	73.5
NW - 38	38	38	45	32	50	60	12	28	58	77.5
NW - 40	40	40	46	32	55	60	12	30	65	84.5
NW - 50	50	50	57	40	65	75	12	30	70	91.5
NW - 1/8	1/8	10.5	16	8	17	19	7	15	34	45.5
NW - 1/4	1/4	13.8	19	11	22	24	7.5	18	40	52
NW - 3/8	3/8	17.3	24	14	27	32	8	22	44	56.5
NW - 1/2	1/2	21.7	28	18	32	36	9	22	46	58.5
NW - 3/4	3/4	27.2	33	22	41	46	10	25	52	66
NW - 1	1	34.0	40	28	46	55	11	28	56	73.5
NW - 1 1/4	1 1/4	42.7	47	34	60	65	12	28	65	85.5
NW - 1 1/2	1 1/2	48.6	55	40	65	75	12	30	70	91.5

※上記諸元は品質の向上により若干変わることがあります。

1 くい込み式管継手

フレアドユニオン J

J

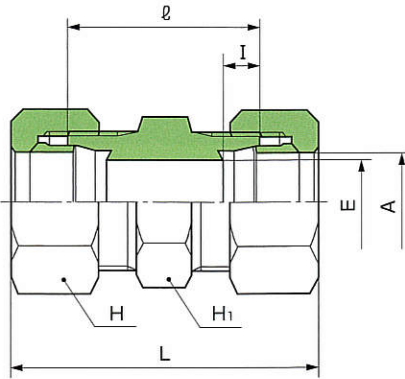

継手の呼び	適用管外径A		E	六角対辺		I	l	手締め L(約)
	呼び径	外径		H ₁	H			
J-4	4	4	2.5	12	12	6	20	35
J-6	6	6	4	14	14	7	30	51
J-8	8	8	6	17	17	7	31	52
J-10	10	10	8	17	19	7	31	54
J-12	12	12	10	19	22	7	31	54
J-15	15	15	12	24	27	7.5	36	61
J-16	16	16	13	27	30	7.5	36	61
J-18	18	18	14	27	32	8	36	61
J-20	20	20	17	30	36	8	38	63
J-22	22	22	18	32	36	9	38	63
J-25	25	25	20	36	41	10	39	66
J-28	28	28	22	41	46	10	43	71
J-30	30	30	25	41	46	10	43	72
J-32	32	32	26	46	50	11	44	73
J-35	35	35	28	46	55	11	44	79
J-38	38	38	32	50	60	12	46	85
J-40	40	40	32	55	60	12	55	94
J-42	42	42	34	55	60	12	55	94
J-50	50	50	40	65	75	12	60	103
J-1/8	1/8	10.5	8	17	19	7	31	54
J-1/4	1/4	13.8	11	22	24	7.5	36	60
J-3/8	3/8	17.3	14	27	32	8	36	61
J-1/2	1/2	21.7	18	32	36	9	38	63
J-3/4	3/4	27.2	22	41	46	10	43	71
J-1	1	34.0	28	46	55	11	44	79
J-1 1/4	1 1/4	42.7	34	60	65	12	57	98
J-1 1/2	1 1/2	48.6	40	65	75	12	60	103

※Average Values

※上記諸元は品質の向上により若干変わることがあります。

隔壁フレアドユニオン JA

JA

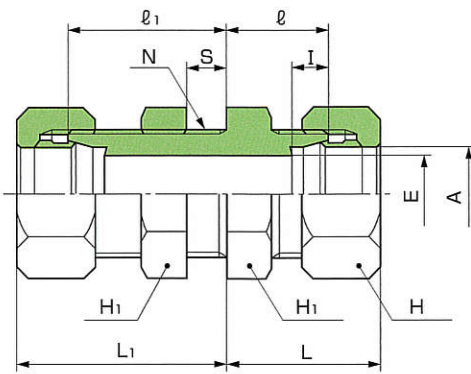

継手の呼び	適用管外径A		E	六角対辺		I	l ₁	l	手締め(約)		N	最大S
	呼び径	外径		H ₁	H				L ₁	L		
JA-4	4	4	2.5	14	12	6	25	14	32.5	21.5	M10x1.25	13
JA-6	6	6	4	17	14	7	32	19	42.5	29.5	M12x1.5	13
JA-8	8	8	6	19	17	7	32	19	42.5	29.5	M14x1.5	13
JA-10	10	10	8	22	19	7	32	20	43.5	31.5	M16x1.5	13
JA-12	12	12	10	24	22	7	32	20	43.5	31.5	M18x1.5	13
JA-15	15	15	12	27	27	7.5	37	22	49.5	34.5	M22x1.5	15
JA-16	16	16	13	30	30	7.5	37	24	49.5	36.5	M24x1.5	15
JA-18	18	18	14	32	32	8	39	24	51.5	36.5	M26x1.5	15
JA-20	20	20	17	32	36	8	39	24	51.5	36.5	M28x1.5	15
JA-22	22	22	18	36	36	9	39	25	51.5	37.5	M30x1.5	15
JA-25	25	25	20	41	41	10	39	25	52.5	38.5	M35x1.5	15
JA-28	28	28	22	46	46	10	41	28	55	42	M38x1.5	15
JA-30	30	30	25	46	46	10	41	28	55.5	42.5	M40x1.5	15
JA-32	32	32	26	50	50	11	43	30	57.5	44.5	M42x1.5	15
JA-35	35	35	28	50	55	11	43	30	60.5	47.5	M45x1.5	15
JA-38	38	38	32	55	60	12	45	31	64.5	50.5	M48x1.5	15
JA-40	40	40	32	60	60	12	50	37	69.5	56.5	M52x2	15
JA-50	50	50	40	70	75	12	50	43	71.5	64.5	M64x2	15
JA-1/8	1/8	10.5	8	22	19	7	32	20	43.5	31.5	M16x1.5	13
JA-1/4	1/4	13.8	11	27	24	7.5	37	22	49	34	M20x1.5	15
JA-3/8	3/8	17.3	14	32	32	8	39	24	51.5	36.5	M26x1.5	15
JA-1/2	1/2	21.7	18	36	36	9	39	25	51.5	37.5	M30x1.5	15
JA-3/4	3/4	27.2	22	46	46	10	41	28	55	42	M38x1.5	15
JA-1	1	34.0	28	50	55	11	43	30	60.5	47.5	M45x1.5	15
JA-1 1/4	1 1/4	42.7	34	65	65	12	50	40	70.5	60.5	M56x2	15
JA-1 1/2	1 1/2	48.6	40	70	75	12	50	43	71.5	64.5	M64x2	15

※Average Values

※上記諸元は品質の向上により若干変わることがあります。

7 くい込み式管継手

ユニオンエルボ

L

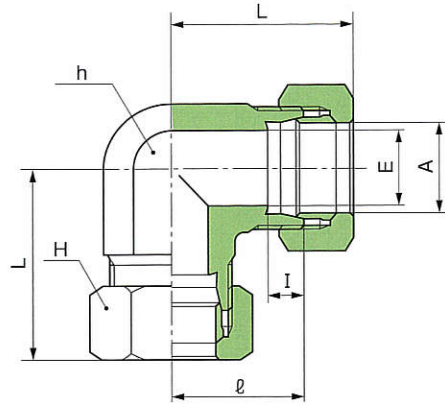

継手の呼び	適用管外径A		E	二面幅 h	六角対辺 H	I	ϕ	手じめ L(約)
	呼び径	外径						
L-6	6		4	14	14	7	20	30.5
L-8	8		6	17	17	7	23	33.5
L-10	10		8	17	19	7	23	34.5
L-12	12		10	19	22	7	24	35.5
L-15	15		12	24	27	7.5	29	41.5
L-16	16		13	27	30	7.5	32	44.5
L-18	18		14	27	32	8	32	44.5
L-20	20		17	30	36	8	33	45.5
L-22	22		18	32	36	9	34	46.5
L-25	25		20	36	41	10	36	49.5
L-28	28		22	41	46	10	41	55
L-30	30		25	41	46	10	41	55.5
L-32	32		26	46	50	11	45	59.5
L-35	35		28	46	55	11	46	63.5
L-38	38		32	50	60	12	50	69.5
L-40	40		32	55	60	12	55	74.5
L-42	42		34	55	60	12	55	74.5
L-50	50		40	65	75	12	62	83.5
L-1/8	1/8	10.5	8	17	19	7	23	34.5
L-1/4	1/4	13.8	11	22	24	7.5	28	40
L-3/8	3/8	17.3	14	27	32	8	32	44.5
L-1/2	1/2	21.7	18	32	36	9	34	46.5
L-3/4	3/4	27.2	22	41	46	10	41	55
L-1	1	34.0	28	46	55	11	46	63.5
L-1 1/4	1 1/4	42.7	34	60	65	12	57	77.5
L-1 1/2	1 1/2	48.6	40	65	75	12	62	83.5

※Average Values

※上記諸元は品質の向上により若干変わることがあります。

ハーフエルボ(メス)

EA

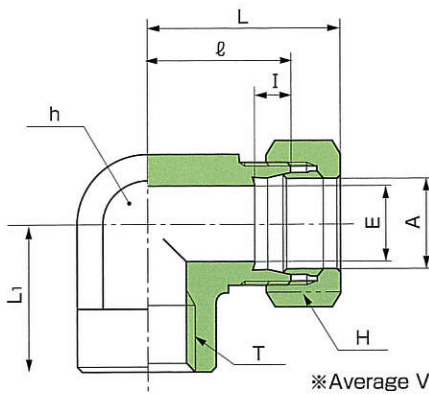

継手の呼び	適用管 外径A	(PT) T	E	二面幅 h	六角対辺 H	I	ϕ	L ₁	手じめ L(約)
EA-8×1/4	8	1/4	6	19	17	7	24	24	34.5
EA-10×1/4	10	1/4	8	19	19	7	24	24	35.5
EA-12×1/4	12	1/4	10	19	22	7	24	24	35.5
EA-12×3/8	12	3/8	10	24	22	7	29	29	40.5
EA-15×3/8	15	3/8	12	24	27	7.5	29	29	41.5
EA-15×1/2	15	1/2	12	30	27	7.5	33	33	45.5
EA-16×1/2	16	1/2	13	30	30	7.5	33	33	45.5
EA-18×1/2	18	1/2	14	30	32	8	33	33	45.5
EA-20×3/4	20	3/4	17	36	36	8	36	36	48.5
EA-22×3/4	22	3/4	18	36	36	9	36	36	48.5
EA-25×3/4	25	3/4	20	36	41	10	36	36	49.5
EA-25×1	25	1	20	46	41	10	46	46	59.5
EA-28×1	28	1	22	46	46	10	46	46	60
EA-30×1 1/4	30	1 1/4	25	55	46	10	55	55	69.5
EA-32×1 1/4	32	1 1/4	26	55	50	11	55	55	69.5
EA-35×1 1/4	35	1 1/4	28	55	55	11	55	55	72.5

※Average Values

※上記諸元は品質の向上により若干変わることがあります。

12 くい込み式管継手

エア抜きバルブ

AP

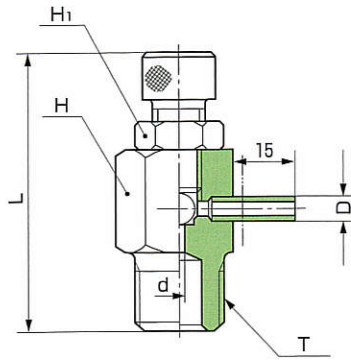

継手の呼び	(PT) T	D	d	六角対辺		L	鋼球
				H ₁	H		
AP - 1/8	1/8	4	3	13	14	51	7/32
AP - 1/4	1/4	4	3	13	14	53	7/32
AP - 3/8	3/8	6	4	13	19	54	7/32
AP - 1/2	1/2	6	4	19	27	69	5/16

※Average Values

※上記諸元は品質の向上により若干変わることがあります。

ホース接続ハーフユニオン(オス)

HJ-K

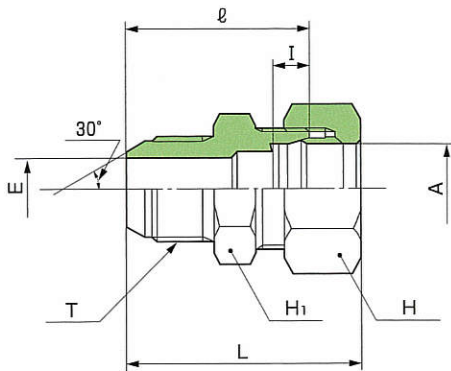

※Average Values

継手の呼び	適用管 外径A	(PF) T	E	六角対辺		I	l	手締め L(約)
				H ₁	H			
HJ-K - 8x1/4	8	1/4	6	17	17	7	35	45.5
HJ-K - 8x3/8	8	3/8	6	19	17	7	37	47.5
HJ-K - 10x1/4	10	1/4	6	17	19	7	35	46.5
HJ-K - 10x3/8	10	3/8	8	19	19	7	37	48.5
HJ-K - 10x1/2	10	1/2	8	22	19	7	40	51.5
HJ-K - 12x1/4	12	1/4	6	19	22	7	35	46.5
HJ-K - 12x3/8	12	3/8	9	19	22	7	37	48.5
HJ-K - 12x1/2	12	1/2	10	22	22	7	40	51.5
HJ-K - 15x3/8	15	3/8	9	24	27	7.5	40	52.5
HJ-K - 15x1/2	15	1/2	12	24	27	7.5	42	54.5
HJ-K - 16x3/8	16	3/8	9	27	30	7.5	40	52.5
HJ-K - 16x1/2	16	1/2	12	27	30	7.5	42	54.5
HJ-K - 18x1/2	18	1/2	12	27	32	8	42	54.5
HJ-K - 20x3/4	20	3/4	16	30	36	8	46	58.5
HJ-K - 22x1/2	22	1/2	12	32	36	9	44	56.5
HJ-K - 22x3/4	22	3/4	16	32	36	9	46	58.5
HJ-K - 25x3/4	25	3/4	16	36	41	10	47	60.5
HJ-K - 25x1	25	1	20	36	41	10	49	62.5
HJ-K - 28x3/4	28	3/4	16	41	46	10	49	63
HJ-K - 28x1	28	1	22	41	46	10	51	65
HJ-K - 30x3/4	30	3/4	16	41	46	10	49	63.5
HJ-K - 30x1	30	1	22	41	46	10	51	65.5
HJ-K - 32x1	32	1	22	46	50	11	52	66.5
HJ-K - 32x1 1/4	32	1 1/4	28	46	50	11	56	70.5

※上記諸元は品質の向上により若干変わることがあります。

ホース接続ハーフユニオン(メス)

HJ-K₂

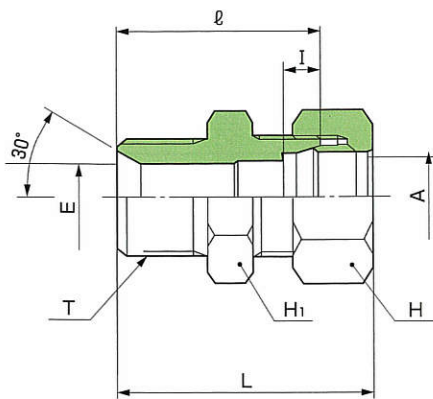

※Average Values

継手の呼び	適用管 外径A	(PF) T	E	六角対辺		I	l	手締め L(約)
				H ₁	H			
HJ-K ₂ - 8x1/4	8	1/4	6	17	17	7	33	43.5
HJ-K ₂ - 8x3/8	8	3/8	6	19	17	7	34	44.5
HJ-K ₂ - 10x1/4	10	1/4	6	17	19	7	33	44.5
HJ-K ₂ - 10x3/8	10	3/8	8	19	19	7	34	45.5
HJ-K ₂ - 10x1/2	10	1/2	8	22	19	7	38	49.5
HJ-K ₂ - 12x1/4	12	1/4	6	19	22	7	33	44.5
HJ-K ₂ - 12x3/8	12	3/8	9	19	22	7	34	45.5
HJ-K ₂ - 12x1/2	12	1/2	10	22	22	7	38	49.5
HJ-K ₂ - 15x3/8	15	3/8	9	24	27	7.5	37	49.5
HJ-K ₂ - 15x1/2	15	1/2	12	24	27	7.5	40	52.5
HJ-K ₂ - 16x3/8	16	3/8	9	27	30	7.5	37	49.5
HJ-K ₂ - 16x1/2	16	1/2	12	27	30	7.5	40	52.5
HJ-K ₂ - 18x1/2	18	1/2	12	27	32	8	40	52.5
HJ-K ₂ - 20x3/4	20	3/4	16	30	36	8	43	55.5
HJ-K ₂ - 22x1/2	22	1/2	12	32	36	9	42	54.5
HJ-K ₂ - 22x3/4	22	3/4	16	32	36	9	43	55.5
HJ-K ₂ - 25x3/4	25	3/4	16	36	41	10	44	57.5
HJ-K ₂ - 25x1	25	1	20	36	41	10	46	59.5
HJ-K ₂ - 28x3/4	28	3/4	16	41	46	10	46	60
HJ-K ₂ - 28x1	28	1	22	41	46	10	48	62
HJ-K ₂ - 30x3/4	30	3/4	16	41	46	10	46	60.5
HJ-K ₂ - 30x1	30	1	22	41	46	10	48	62.5
HJ-K ₂ - 32x1	32	1	22	46	50	11	49	63.5
HJ-K ₂ - 32x1 1/4	32	1 1/4	28	46	50	11	55	69.5
HJ-K ₂ - 38x1 1/2	38	1 1/2	32	50	60	12	57	76.5
HJ-K ₂ - 40x1 1/2	40	1 1/2	32	55	60	12	62	81.5
HJ-K ₂ - 50x2	50	2	40	65	75	12	70	91.5

※上記諸元は品質の向上により若干変わることがあります。

13 くい込み式管継手

ホース接続ハーフエルボ(オス) **HJM**

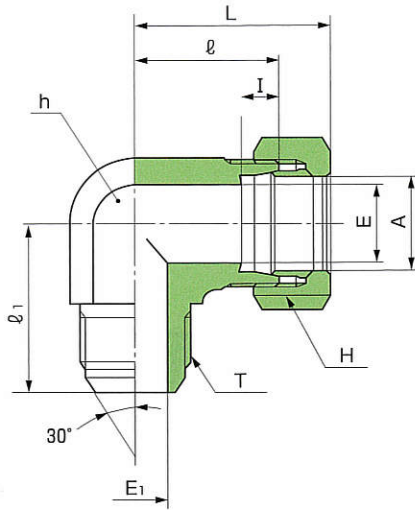

※Average Values

継手の呼び	適用管 外径A	(PF) T	E	E ₁	二面幅 h	六角対辺 H	I	ℓ ₁	ℓ	手締め L(約)
HJM - 8×1/4	8	1/4	6	6	17	17	7	25	23	33.5
HJM - 8×3/8	8	3/8	6	9	19	17	7	28	24	34.5
HJM - 10×1/4	10	1/4	8	6	19	19	7	28	24	35.5
HJM - 10×3/8	10	3/8	8	9	19	19	7	28	24	35.5
HJM - 10×1/2	10	1/2	8	12	24	19	7	34	29	40.5
HJM - 12×1/4	12	1/4	10	6	19	22	7	28	24	35.5
HJM - 12×3/8	12	3/8	10	9	19	22	7	28	24	35.5
HJM - 12×1/2	12	1/2	10	12	24	22	7	34	29	40.5
HJM - 15×3/8	15	3/8	12	9	24	27	7.5	33	29	41.5
HJM - 15×1/2	15	1/2	12	12	24	27	7.5	34	29	41.5
HJM - 16×3/8	16	3/8	13	9	27	30	7.5	36	32	44.5
HJM - 16×1/2	16	1/2	13	12	27	30	7.5	38	32	44.5
HJM - 18×1/2	18	1/2	14	12	27	32	8	38	32	44.5
HJM - 20×3/4	20	3/4	17	16	30	36	8	41	33	45.5
HJM - 22×1/2	22	1/2	18	12	32	36	9	40	34	46.5
HJM - 22×3/4	22	3/4	18	16	32	36	9	42	34	46.5
HJM - 25×3/4	25	3/4	20	16	36	41	10	44	36	49.5
HJM - 25×1	25	1	20	20	36	41	10	46	36	49.5
HJM - 28×3/4	28	3/4	22	16	41	46	10	47	41	55
HJM - 28×1	28	1	22	22	41	46	10	49	41	55
HJM - 30×3/4	30	3/4	25	16	41	46	10	47	41	55.5
HJM - 30×1	30	1	25	22	41	46	10	49	41	55.5
HJM - 32×1	32	1	26	22	46	50	11	54	46	60.5
HJM - 32×1 1/4	32	1 1/4	26	28	46	50	11	56	46	60.5

※上記諸元は品質の向上により若干変わることがあります。

ナット **C**

C

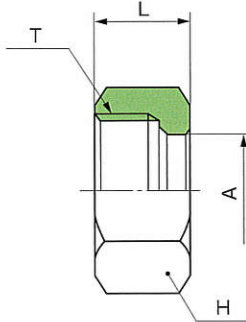

※Average Values

継手の呼び	適用管外径A 呼び径 外径	T	六角対辺 H	L	
C - 4	4	M10×1.25	12	10.5	
C - 6	6	M12×1.5	14	15	
C - 8	8	M14×1.5	17	15	
C - 10	10	M16×1.5	19	16	
C - 12	12	M18×1.5	22	16	
C - 15	15	M22×1.5	27	19	
C - 16	16	M24×1.5	30	19	
C - 18	18	M26×1.5	32	19	
C - 20	20	M28×1.5	36	19	
C - 22	22	M30×1.5	36	19	
C - 25	25	M35×1.5	41	20	
C - 28	28	M38×1.5	46	21	
C - 30	30	M40×1.5	46	22	
C - 32	32	M42×1.5	50	22	
C - 35	35	M45×1.5	55	25	
C - 38	38	M48×1.5	60	27	
C - 40	40	M52×2	60	29.5	
C - 42	42	M52×2	60	29.5	
C - 50	50	M64×2	75	31.5	
C - 1/8	1/8	10.5	M16×1.5	19	16
C - 1/4	1/4	13.8	M20×1.5	24	18
C - 3/8	3/8	17.3	M26×1.5	32	19
C - 1/2	1/2	21.7	M30×1.5	36	19
C - 3/4	3/4	27.2	M38×1.5	46	21
C - 1	1	34.0	M45×1.5	55	25
C - 1 1/4	1 1/4	42.7	M56×2	65	30.5
C - 1 1/2	1 1/2	48.6	M64×2	75	31.5

※適用管φ22と1/2B用のナットは共通です。

スリーブ **D**

D

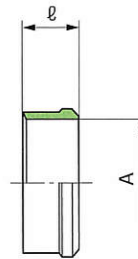

※Average Values

継手の呼び	適用管外径A 呼び径 外径	ℓ	
D - 4	4	7	
D - 6	6	9	
D - 8	8	9	
D - 10	10	10	
D - 12	12	10	
D - 15	15	10	
D - 16	16	10	
D - 18	18	10	
D - 20	20	10	
D - 22	22	10	
D - 25	25	11	
D - 28	28	11	
D - 30	30	11	
D - 32	32	11	
D - 35	35	14	
D - 38	38	14	
D - 40	40	14	
D - 42	42	14	
D - 50	50	14	
D - 1/8	1/8	10.5	10
D - 1/4	1/4	13.8	10
D - 3/8	3/8	17.3	10
D - 1/2	1/2	21.7	10
D - 3/4	3/4	27.2	11
D - 1	1	34.0	14
D - 1 1/4	1 1/4	42.7	14
D - 1 1/2	1 1/2	48.6	14

※上記諸元は品質の向上により若干変わることがあります。