

# MINIATURE VALVES

## VU

計装用

### MINIATURE VALVE

ミニチュアバルブ(ユニオン型)

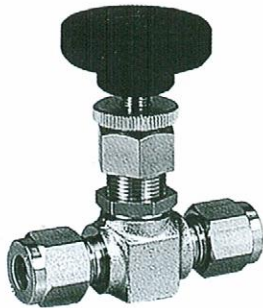

(METRIC)

(Unit:mm)

PART. No.	D	d	L	H	W	B	PANEL HOLE SIZE
VU- 3-0	3	1.6	64	58.5	35	12	14.5
VU- 4-0	4	2.6	58.6	58.5	35	14	14.5
VU- 6-0	6	3	58.8	58.5	35	14	14.5
VU- 8-0	8	3	59.6	58.5	35	15.87	14.5
VU-10-0	10	3	65.4	58.5	35	19	14.5

(INCHES)

※管外径5φも製作しております。

VU- 01-0	1/8" : 3.18	1.6	64	58.5	35	12	14.5
VU- 02-0	1/4" : 6.35	3	58.8	58.5	35	14	14.5
VU-025-0	5/16" : 7.94	3	59.6	58.5	35	15.87	14.5
VU- 03-0	3/8" : 9.53	3	63.6	58.5	35	17.46	14.5

(SCHEDULE)

※管外径3/8φも製作しております。

VU-10.5-0	1/8"B : 10.5	3	64.4	58.5	35	19	14.5
-----------	--------------	---	------	------	----	----	------

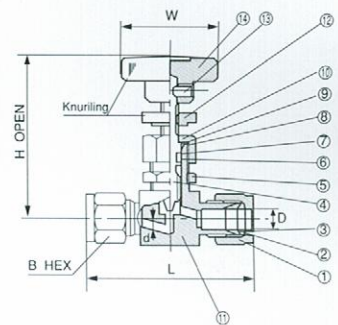

No.	NAME	MATERIAL
1	NUT	SUS-316
2	FRONT FERRULE	SUS-316
3	REAR FERRULE	SUS-316
4	STEM	SUS-316
5	MOUNTING NUT	SUS-316
6	"O" RING	VITON
7	BACK UP RING	TEFLON
8	WASHER	SUS-304
9	STOP RING	RUBBER
10	NUT	SUS-316
11	BODY	SUS-316
12	STOP NUT	BSBM
13	SET BOLT	STEEL
14	HANDLE	NYLON

SPECIFICATIONS

MAX PRESSURE RATING : 35kgf/cm<sup>2</sup> (3.5MPa)  
MAX TEMPERATURE RATING : 100°C

## VH

計装用

### MINIATURE VALVE

ミニチュアバルブ(ハーフ型)

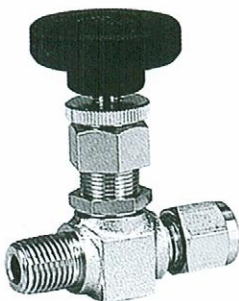

(METRIC)

(Unit:mm)

PART. No.	D	P PT or NPT	d	L	H	W	B	PANEL HOLE SIZE
VH- 3-1	3	1/8"	1.6	54	58.5	35	12	14.5
VH- 4-1	4	1/4"	2.6	51.3	58.5	35	14	14.5
VH- 6-1	6	1/8"	3	52.4	58.5	35	14	14.5
VH- 6-2	6	1/4"	3	54.4	58.5	35	14	14.5
VH- 8-2	8	1/4"	3	54.8	58.5	35	15.87	14.5
VH- 8-3	8	3/8"	3	54.8	58.5	35	15.87	14.5
VH-10-2	10	1/4"	3	57.7	58.5	35	19	14.5
VH-10-3	10	3/8"	3	57.7	58.5	35	19	14.5

(INCHES)

※管外径5φも製作しております。

VH- 01-1	1/8" : 3.18	1/8"	1.6	54	58.5	35	12	14.5
VH- 02-1	1/4" : 6.35	1/8"	3	52.4	58.5	35	14	14.5
VH- 02-2	1/4" : 6.35	1/4"	3	54.4	58.5	35	14	14.5
VH-025-2	5/16" : 7.94	1/4"	3	54.8	58.5	35	14	14.5
VH- 03-2	3/8" : 9.53	1/4"	3	57.7	58.5	35	17.46	14.5
VH- 03-3	3/8" : 9.53	3/8"	3	57.7	58.5	35	17.46	14.5

(SCHEDULE)

※管外径3/8φも製作しております。

VH-10.5-2	1/8"B : 10.5	1/4"	3	57.2	58.5	35	19	14.5
VH-10.5-3	1/8"B : 10.5	3/8"	3	57.2	58.5	35	19	14.5

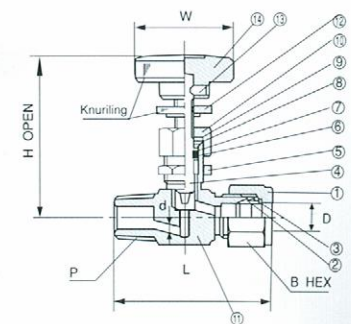

No.	NAME	MATERIAL
1	NUT	SUS-316
2	FRONT FERRULE	SUS-316
3	REAR FERRULE	SUS-316
4	STEM	SUS-316
5	MOUNTING NUT	SUS-316
6	"O" RING	VITON
7	BACK-UP RING	TEFLON
8	WASHER	SUS-304
9	STOP RING	RUBBER
10	NUT	SUS-316
11	BODY	SUS-316
12	STOP NUT	BSBM
13	SET BOLT	STEEL
14	HANDLE	NYLON

SPECIFICATIONS

MAX PRESSURE RATING : 20kgf/cm<sup>2</sup> (2MPa)  
MAX TEMPERATURE RATING : 100°C

# VL

■計装用

## MINIATURE VALVE

ミニチュアバルブ (L型)

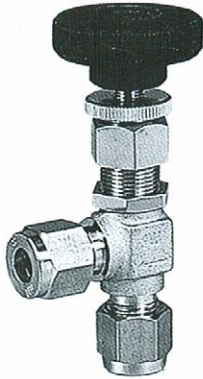

(METRIC)

(Unit:mm)

PART. No.	D	d	L	H	W	B	PANEL HOLE SIZE
VL- 3-0	3	1.6	32	58.5	35	12	14.5
VL- 4-0	4	2.6	29.3	58.5	35	14	14.5
VL- 6-0	6	3	29.4	58.5	35	14	14.5
VL- 8-0	8	3	29.8	58.5	35	15.87	14.5
VL-10-0	10	3	32.7	58.5	35	19	14.5

(INCHES)

※管外径5φも製作しております。

VL- 01-0	1/8" : 3.18	1.6	32	58.5	35	12	14.5
VL- 02-0	1/4" : 6.35	3	29.4	58.5	35	14	14.5
VL-025-0	5/16" : 7.94	3	29.8	58.5	35	15.87	14.5
VL- 03-0	3/8" : 9.53	3	31.8	58.5	35	17.46	14.5

(SCHEDULE)

※管外径3/16"も製作しております。

VL-10.5-0	1/8"B: 10.5	3	32.2	58.5	35	19	14.5
-----------	-------------	---	------	------	----	----	------

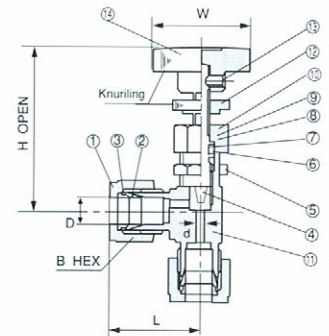

No.	NAME	MATERIAL
1	NUT	SUS-316
2	FRONT FERRULE	SUS-316
3	REAR FERRULE	SUS-316
4	STEM	SUS-316
5	MOUNTING NUT	SUS-316
6	"O" RING	VITON
7	BACK-UP RING	TEFLON
8	WASHER	SUS-304
9	STOP RING	RUBBER
10	NUT	SUS-316
11	BODY	SUS-316
12	STOP NUT	BSBM
13	SET BOLT	STEEL
14	HANDLE	NYLON

SPECIFICATIONS

MAX PRESSURE RATING : 20kgf/cm<sup>2</sup> (2MPa)  
MAX TEMPERATURE RATING : 100°C

# VE

■計装用

## MINIATURE VALVE

ミニチュアバルブ (エルボ型)

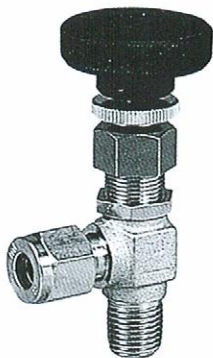

(METRIC)

(Unit:mm)

PART. No.	D	P PT or NPT	d	L <sub>1</sub>	L <sub>2</sub>	H	W	B	PANEL HOLE SIZE
VE- 3-1	3	1/8"	1.6	32	23	58.5	35	12	14.5
VE- 4-1	4	1/8"	2.6	29.3	23	58.5	35	14	14.5
VE- 6-1	6	1/8"	3	29.4	23	58.5	35	14	14.5
VE- 6-2	6	1/4"	3	29.4	25	58.5	35	14	14.5
VE- 8-2	8	1/4"	3	29.8	25	58.5	35	15.87	14.5
VE- 8-3	8	3/8"	3	29.8	25	58.5	35	15.87	14.5
VE-10-2	10	1/4"	3	32.7	25	58.5	35	19	14.5
VE-10-3	10	3/8"	3	32.7	25	58.5	35	19	14.5

(INCHES)

※管外径5φも製作しております。

VE- 01-1	1/8" : 3.18	1/8"	1.6	32	23	58.5	35	12	14.5
VE- 02-1	1/4" : 6.35	1/8"	3	29.4	23	58.5	35	14	14.5
VE- 02-2	1/4" : 6.35	1/4"	3	29.4	25	58.5	35	14	14.5
VE-025-2	5/16" : 7.94	1/4"	3	29.8	25	58.5	35	15.87	14.5
VE- 03-2	3/8" : 9.53	1/4"	3	31.8	25	58.5	35	17.46	14.5
VE- 03-3	3/8" : 9.53	3/8"	3	31.8	25	58.5	35	17.46	14.5

(SCHEDULE)

※管外径3/16"も製作しております。

VE-10.5-2	1/8"B: 10.5	1/4"	3	32.2	25	58.5	35	19	14.5
VE-10.5-3	1/8"B: 10.5	3/8"	3	32.2	25	58.5	35	19	14.5

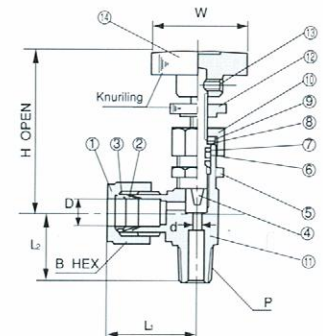

No.	NAME	MATERIAL
1	NUT	SUS-316
2	FRONT FERRULE	SUS-316
3	REAR FERRULE	SUS-316
4	STEM	SUS-316
5	MOUNTING NUT	SUS-316
6	"O" RING	VITON
7	BACK-UP RING	TEFLON
8	WASHER	SUS-304
9	STOP RING	RUBBER
10	NUT	SUS-316
11	BODY	SUS-316
12	STOP NUT	BSBM
13	SET BOLT	STEEL
14	HANDLE	NYLON

SPECIFICATIONS

MAX PRESSURE RATING : 20kgf/cm<sup>2</sup> (2MPa)  
MAX TEMPERATURE RATING : 100°C